

BLE

Bluetooth Low Energy Modules

SBC2112-B



Preliminary Specification

Version 1.0

23-JUN.-2014

Content

1. Description.....	3
2. Features.....	3
3. Block Diagram.....	3
4. Radio Characteristics.....	4
5. Electrical Characteristics.....	4
6. Software Diagram.....	6
7. Pin Definition.....	6
8. Mechanical Specification.....	9
9. Reference Schematics.....	10
10. UART Interface.....	10
11. Serial Peripheral Interface.....	11
12. Programmable I/O Ports, PIO and AIO.....	11
13. LED Flasher / PWM Module.....	12
14. Key Bluetooth Profiles.....	12
15. Firmware.....	12
16. Default setting Information.....	12
17. Reflow information.....	13
18. Certification.....	16

1. Description

SBC2112-B transmitter/Receiver Bluetooth module is power by CSR CSR1010 technology. That provides a complete 2.4GHz Bluetooth technology for Bluetooth Low Energy transmission. The SBC2112-B module is compliant with Bluetooth specification,4.0 LE and support Heart rate, Glucose meter, Blood Pressure, Thermometer, Proximity tag, Phone alert, status and notification profile. It is the 7.5dBm module with build in antenna. Reduce the effort on the RF section when the engineer designs it into the system. Smart Design also customize the software to meet the requirement from customer.

2. Features

CSR BlueCore1010 Chip.

Bluetooth 4.0 LE Compliant.

Bluetooth 7.5dBm RF output power. 10~50 meters transmission distance.

5 GPIO

3 AIO

10 bit ADC

UART digital interface.

Fully configurable with simple AT style commands over UART and Bluetooth connections.

Build in high performance chip antenna.

Dimension: 21.0 X 12.7 X 3.0mm.

LGA(Land Grid Array) pads reliable PCB mounting.

Support Dual Mode: Master and Slave mode

CE, FCC Certified

3. Block Diagram

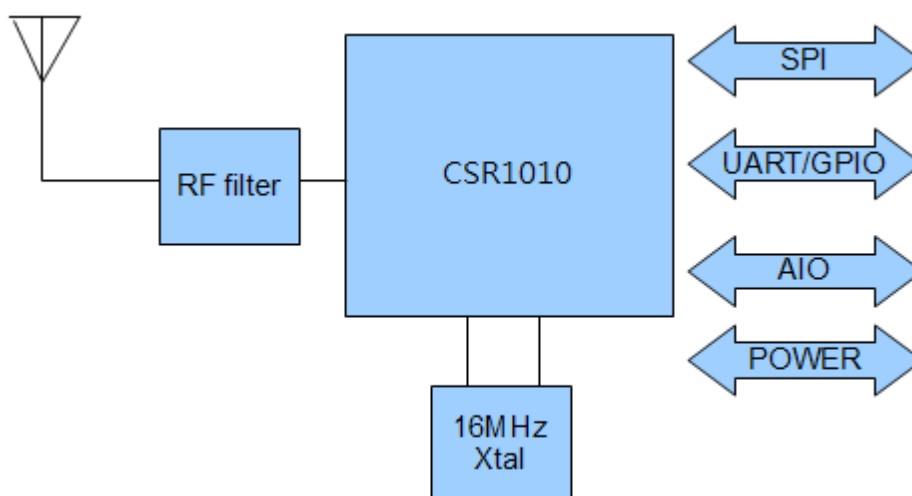

SBC2112-B Module Block Diagram

4. Radio Characteristics

	Frequency (GHz)	MIN	TYP	MAX	BT Spec	Unit
Sensitivity at 0.1%BER	2.402	≤-92	-85	-	≤ -70	dBm
	2.441	≤-92	-85	-		dBm
	2.480	≤-92	-85	-		dBm
RF Transmit Power	2.402	0	3	7.5	≤ 4	dBm
	2.441	0	3	7.5		dBm
	2.480	0	3	7.5		dBm

5. Electrical Characteristics

Power Consumption

Mode	Description	Total Typical Current at 3V
Dormant	All functions are shutdown. To wake up toggle the WAKE pin.	<600nA
Hibernate	VDD_PADS = ON, REFCLK = OFF, SLEEPCLK = ON, VDD_BAT = ON	<1.5μA
Deep sleep	VDD_PADS = ON, REFCLK = OFF, SLEEPCLK = ON, VDD_BAT = ON, RAM = ON, digital circuits = ON, SMPS = ON (low-power mode), 1ms wake-up time	<5μA
Idle	VDD_PADS = ON, REFCLK = ON, SLEEPCLK = ON, VDD_BAT = ON, RAM = ON, digital circuits = ON, MCU = IDLE, <1μs wake-up time	~1mA
RX / TX active	-	~16mA @ 3V peak current

Voltage Input

	MIN	Typ.	MAX	Unit
Supply Voltage	3.1	3.3	3.5	V

Operating Conditions

Voltage Range	3.3V±0.2V
Operating Temperature Range	-40C ~ 85°C
Storage Temperature Range	-40°C ~ 85°C
Relative Humidity (Operating)	≤90%
Relative Humidity (Storage)	≤90%

AIO

Input Voltage Levels	Min	Typ	Max	Unit
Input voltage	0	-	1.3	V

Digital Terminals

Input Voltage Levels	Min	Typ	Max	Unit
V _{IL} input logic level low	-0.4	-	0.4	V
V _{IH} input logic level high	0.7 x VDD	-	VDD + 0.4	V
T _r /T _f	-	-	25	ns

Output Voltage Levels	Min	Typ	Max	Unit
V _{OL} output logic level low, I _{OL} = 4.0mA	-	-	0.4	V
V _{OH} output logic level high, I _{OH} = -4.0mA	0.75 x VDD	-	-	V
T _r /T _f	-	-	5	ns

Input and Tristate Currents	Min	Typ	Max	Unit
With strong pull-up	-150	-40	-10	μA
PC with strong pull-up	-250	-	-	μA
With strong pull-down	10	40	150	μA
With weak pull-up	-5.0	-1.0	-0.33	μA
With weak pull-down	0.33	1.0	5.0	μA
C _i input capacitance	1.0	-	5.0	pF

6. Software Diagram

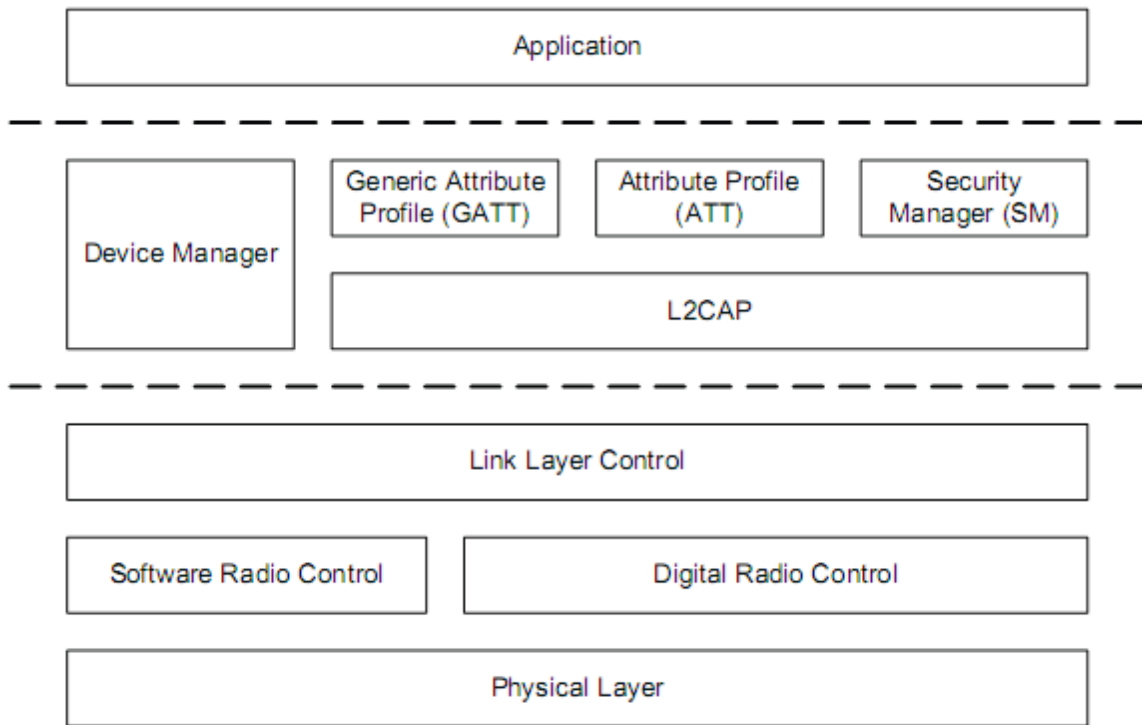

7. Pin Definition

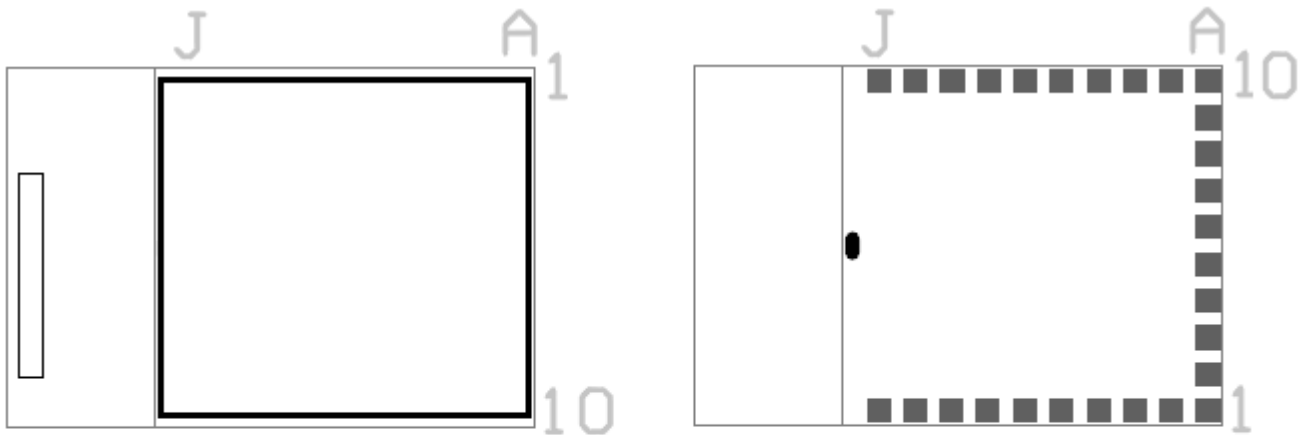

Top View

Bottom View

PIN	Name	Type	Note
A1	VDD_PADS	PWR	Voltage level for GPIO. Input VDD to set the voltage level of GPIO
A2	SPI_PIO_SEL	I	Selects SPI debug on PIO[8:5].
A3	GPIO11	I/O	Programmable I/O line. (reserved to wake up deep sleep)
A4	GPIO10	I/O	Programmable I/O line.
A5	GPIO9	I/O	Programmable I/O line.
A6	GPIO8	I/O	Programmable I/O line or debug SPI MISO selected by SPI_PIO#. Same voltage level as VDD_PADS.
A7	GPIO7	I/O	Programmable I/O line or debug SPI MOSI selected by SPI_PIO#. Same voltage level as VDD_PADS.
A8	GPIO6	I/O	Programmable I/O line or debug SPI chip select (CS#) selected by SPI_PIO#. Same voltage level as VDD_PADS.
A9	GPIO5	I/O	Programmable I/O line or debug SPI CLK selected by SPI_PIO#. Same voltage level as VDD_PADS.
A10	GND	PWR	Ground
B1	GND	PWR	Ground
C1	GND	PWR	Ground
D1	GND	PWR	Ground
E1	GND	PWR	Ground
F1	GND	PWR	Ground
G1	GND	PWR	Ground
H1	GND	PWR	Ground
I1	GND	PWR	Ground
J1	VBAT	PWR	Main Power input 1.8V – 3.6V
B10	GPIO1/UART RX	I/O	Programmable I/O line or UART RX.
C10	GPIO0/UART TX	I/O	Programmable I/O line or UART TX.
D10	AIO0	I/O	Analogue programmable I/O line 0..
E10	AIO1	I/O	Analogue programmable I/O line 1.
F10	AIO2	I/O	Analogue programmable I/O line 2.
G10	GND	PWR	Ground
H10	GND	PWR	Ground
I10	GND	PWR	Ground
J10	RF	RF	Bluetooth transmitter / receiver.

VBAT

Supply main voltage at this pin with 1.8V~3.6 V.

GND

Connect GND pins to the ground plane of the PCB.

VDD_PADS

Supply voltage at this pin to set the GPIO voltage level. The input voltage is from 1.8V to 3.6V

PIO0,1, 5 -11

Programmable digital I/O lines. All PIO lines can be configured through software to have either weak or strong pull-ups or pull-downs. Configuration for each PIO line depends on the application. Please check Default configuration in Standard Setup Information.

AIO0,1,2

AIO can be used to monitor analogue voltages such as a temperature sensor etc.

UART_RX

A CMOS input with a weak internal pull-down. RXD is used to implement UART data transfer from another device to MB-C05. The UART interface requires an external RS232 transceiver chip.

UART_TX

A CMOS output with a weak internal pull-up. TXD is used to implement UART data transfer from MB-C05 to another device. The UART interface requires external RS232 transceiver chip.

SPI_CSB

A CMOS input with a weak internal pull-down for debug mode.

SPI_CLK

A CMOS input for the SPI clock signal for debug mode.

SPI_MISO

An SPI data output for debug mode.

SPI_MOSI

An SPI data input for debug mode.

8. Mechanical Specification

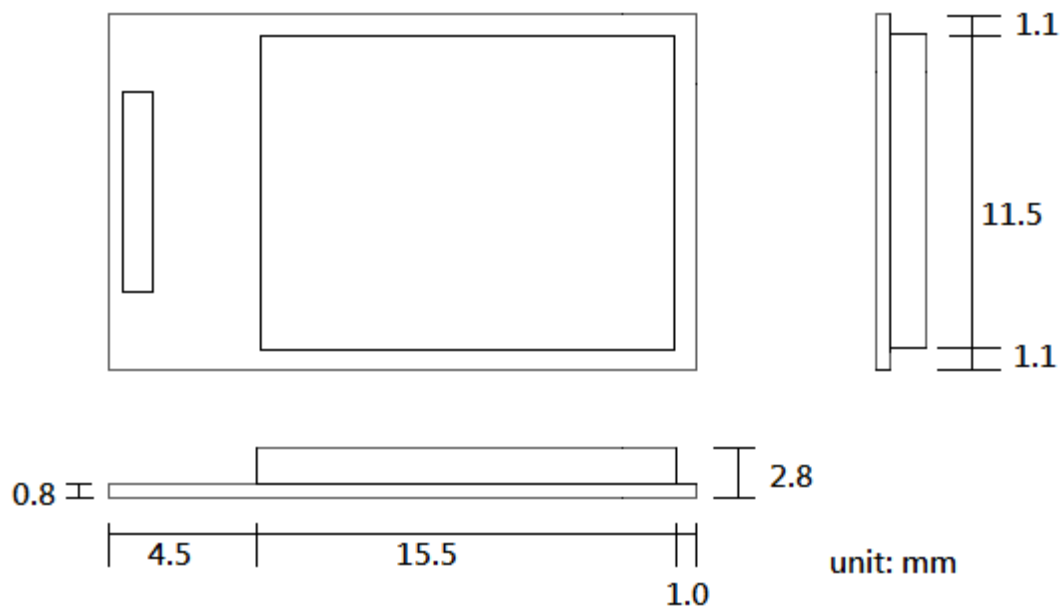
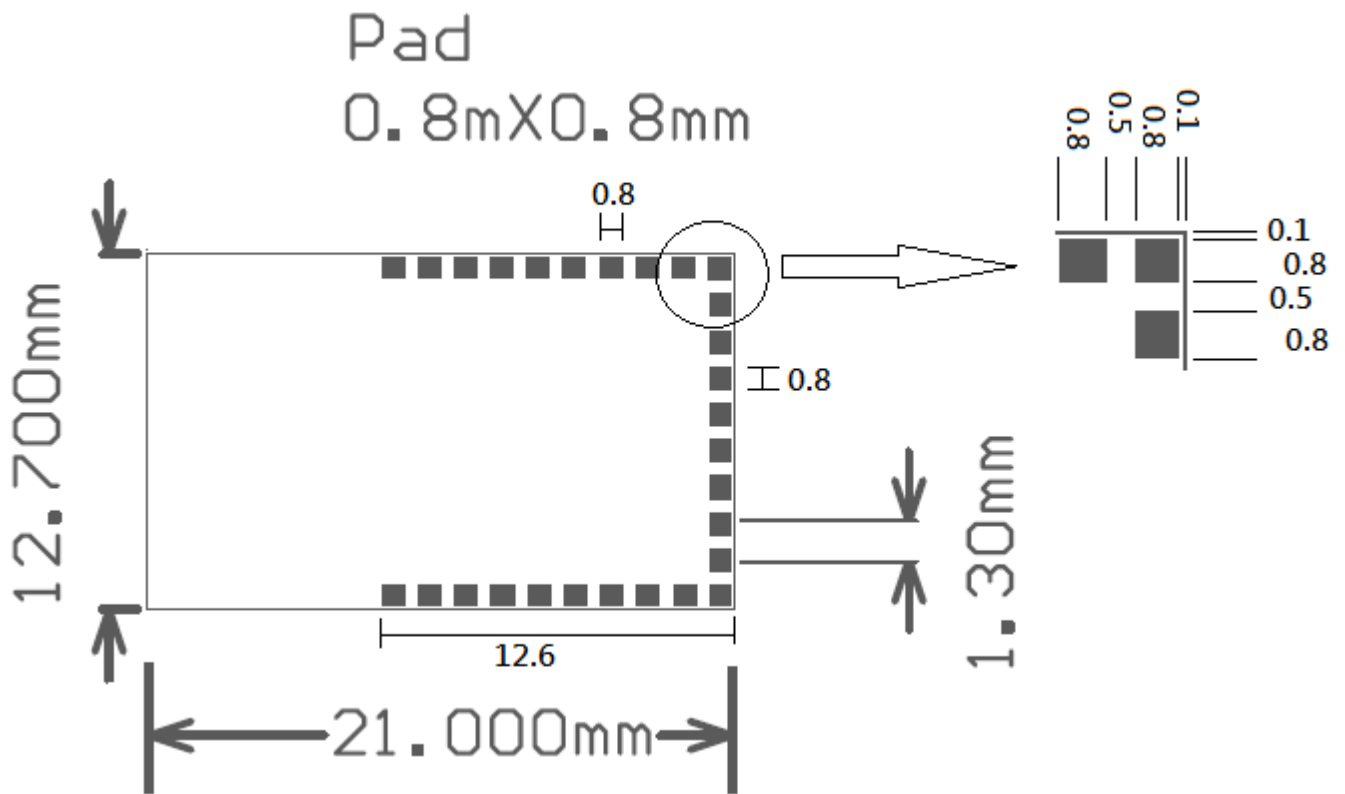

9. Reference Schematics

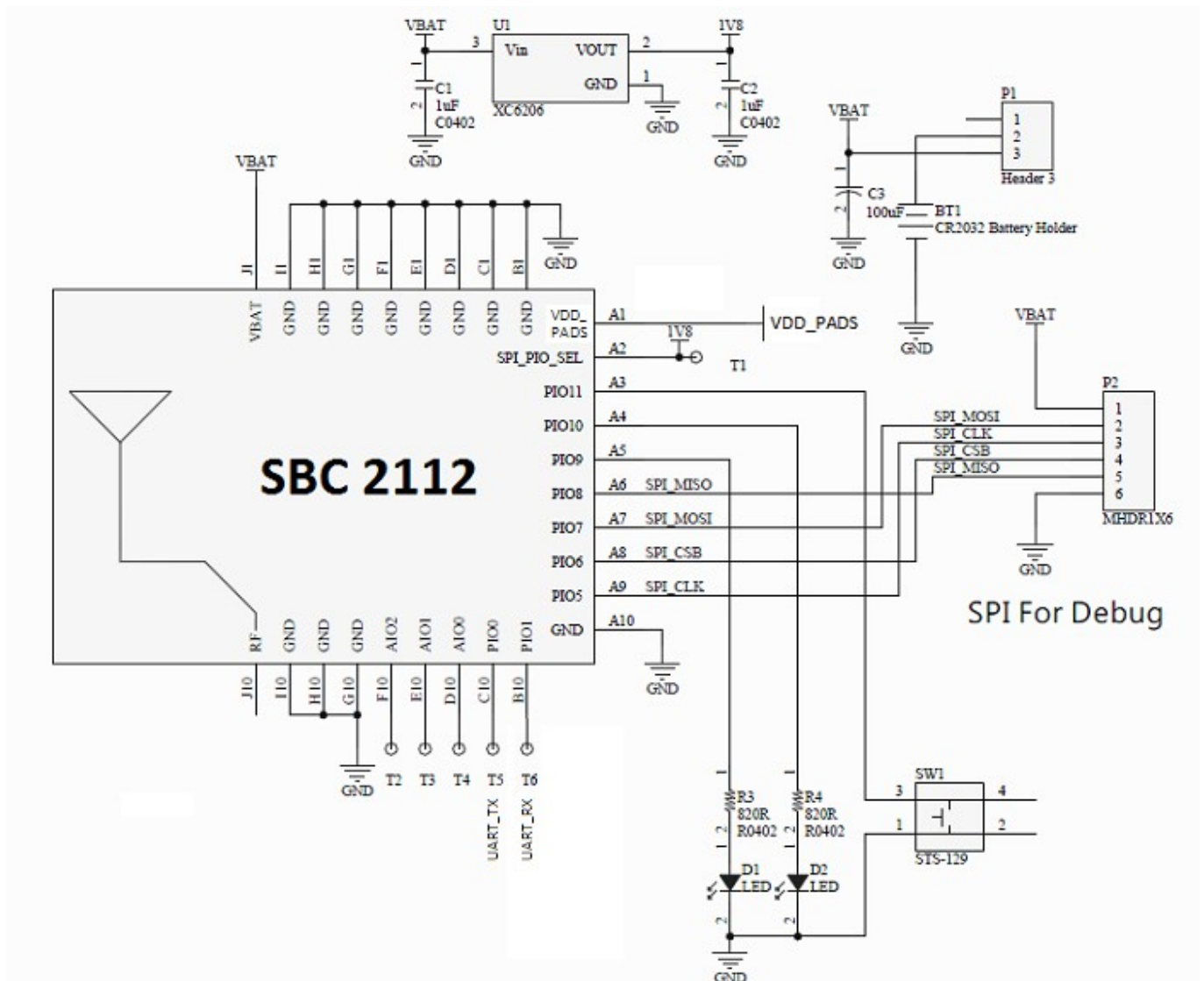

10. UART Interface

The SBC2112-B UART interface provides a simple mechanism for communicating with other serial devices using the RS232 protocol. 2 signals implement the UART function, UART_TX and UART_RX. When SBC2112-B is connected to another digital device, UART_RX and UART_TX transfer data between the 2 devices. UART configuration parameters, e.g. baud rate and data format, are set using SBC2112-B firmware. When selected in firmware PIO[0] is assigned to a UART_TX output and PIO[1] is assigned to a UART_RX input, The UART CTS and RTS signals can be assigned to any PIO pin by the on-chip firmware.

Note:

To communicate with the UART at its maximum data rate using a standard PC, the PC requires an

accelerated serial port adapter card.

Parameter		Possible Values
Baud rate	Minimum	1200 baud ($\leq 2\%$ Error)
		9600 baud ($\leq 1\%$ Error)
	Maximum	2Mbaud ($\leq 1\%$ Error)
Flow control		CTS / RTS
Parity		None, Odd or Even
Number of stop bits		1 or 2
Bits per byte		8

UART Configuration While in Deep Sleep

The maximum baud rate is 9600 baud during deep sleep.

11. Serial Peripheral Interface

The SBC2112-B debug SPI interface is available in SPI slave mode to enable an external MCU to program and control the SBC2112-B, generally via libraries or tools supplied by CSR. The protocol of this interface is proprietary. The 4 SPI debug lines directly support this function.

The SPI programs, configures and debugs the SBC2112-B. It is required in production. Ensure the 4 SPI signals are brought out to either test points or a header. Take SPI_PIO#_SEL high to enable the SPI debug feature on PIO[8:5]. SBC2112-B uses a 16-bit data and 16-bit address programming and debug interface. Transactions occur when the internal processor is running or is stopped.

12. Programmable I/O Ports, PIO and AIO

9 lines of programmable bidirectional I/O are provided. PIO lines are software-configurable as weak pull-up, weak pull-down, strong pull-up or strong pull-down.

Note:

At reset all PIO lines are inputs with weak pull-downs.

Any of the PIO lines can be configured as interrupt request lines or as wake-up lines from sleep modes.

The SBC2112-B supports alternative functions on the PIO lines:

- SPI interface, s
- UART,
- LED flasher / PWM module

Note:

CSR cannot guarantee that the PIO assignments remain as described. Implementation of the PIO lines is firmware build-specific, for more information see the relevant software release note. SBC2112-B has 3 general-purpose analogue interface pins, AIO[2:0].

13. LED Flasher / PWM Module

SBC2112-B contains a LED flasher / PWM module that works in sleep modes. These functions are controlled by the on-chip firmware.

14. Key Bluetooth Profiles

- Heart rate (Supported)
- Glucose meter (Supported)
- Blood Pressure (default)
- Thermometer (Supported)

15. Firmware

1. BLE-AT firmware

Please check with BLE-AT commands manual.

16. Default setting Information

Parameter		
1	Baud Rate	115200
2	Pin Code Prompt	
3	Local Name	
4	Master/Slave	

17. Reflow information

Reflow Profile Graphic, assuming:

Kester R905 Sn/4Ag/0.5Cu solder paste.

All solder ball alloys melt at 217°C.

Component joints do not exceed temperatures as per J-STD-02

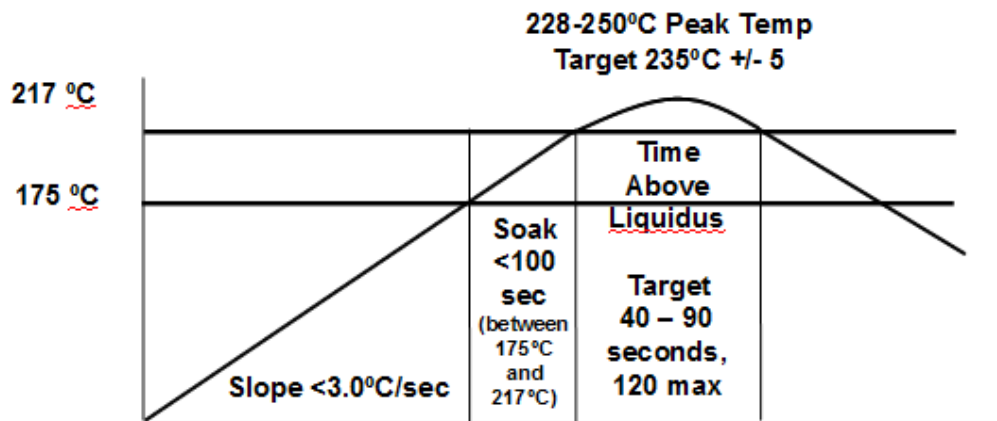

Federal Communications Commission (FCC) Statement

15.21

You are cautioned that changes or modifications not expressly approved by the part responsible for compliance could void the user's authority to operate the equipment.

15.105(b)

This equipment has been tested and found to comply with the limits for a Class B digital device, pursuant to part 15 of the FCC rules. These limits are designed to provide reasonable protection against harmful interference in a residential installation. This equipment generates, uses and can radiate radio frequency energy and, if not installed and used in accordance with the instructions, may cause harmful interference to radio communications. However, there is no guarantee that interference will not occur in a particular installation. If this equipment does cause harmful interference to radio or television reception, which can be determined by turning the equipment off and on, the user is encouraged to try to correct the interference by one or more of the following measures:

- Reorient or relocate the receiving antenna.**
- Increase the separation between the equipment and receiver.**
- Connect the equipment into an outlet on a circuit different from that to which the receiver is connected.**
- Consult the dealer or an experienced radio/TV technician for help.**

This device complies with Part 15 of the FCC Rules. Operation is subject to the following two conditions:

- 1) this device may not cause harmful interference and**
- 2) this device must accept any interference received, including interference that may cause undesired operation of the device.**

FCC RF Radiation Exposure Statement:

This equipment complies with FCC radiation exposure limits set forth for an uncontrolled environment. End users must follow the specific operating instructions for satisfying RF exposure compliance. This transmitter must not be co-located or operating in conjunction with any other antenna or transmitter.

USERS MANUAL OF THE END PRODUCT:

The end user has to be informed that the FCC radio-frequency exposure guidelines for an uncontrolled environment can be satisfied. The end user has to also be informed that any changes or modifications not expressly approved by the manufacturer could void the user's authority to operate this equipment. If the size of the end product is smaller than 8x10cm, then additional FCC part 15.19 statement is required to be

available in the users manual: This device complies with Part 15 of FCC rules. Operation is subject to the following two conditions: (1) this device may not cause harmful interference and (2) this device must accept any interference received, including interference that may cause undesired operation.

LABEL OF THE END PRODUCT:

The final end product must be labeled in a visible area with the following " Contains TX FCC ID: W94-SBC2112B ". If the size of the end product is larger than 8x10cm, then the following FCC part 15.19 statement has to also be available on the label: This device complies with Part 15 of FCC rules. Operation is subject to the following two conditions: (1) this device may not cause harmful interference and (2) this device must accept any interference received, including interference that may cause undesired operation.

18. Certification

TCB



Report No.: ER/2014/60004
Issue Date: Jun. 20, 2014
Page: 2 of 40

VERIFICATION OF COMPLIANCE

Applicant: Smart Design Technology Co., Ltd
20F.-8, No.5, Sec. 3, New Taipei Blvd., Xinzhuang Dist., New Taipei City 24250 Taiwan (R.O.C.)

Product Name: BLE BT4.0 Bluetooth Module

Brand Name: Modulestek

Model No.: SBC2112-B, SBC2112

Model Different: N/A

File Number: ER/2014/60004

Date of Test: Jun.05, 2014 ~ Jun. 10, 2014

Date of EUT Received: Jun.05, 2014

Smart Design Tec
20F.-8, No. 107, Se
Taipei,, 24250
Taiwan

Attention: Ming Cl

APPLICABLE STANDARDS	
STANDARD	TEST RESULT
ETSI EN 300 328 V1.8.1:2012	Complied

Grant Notes

Output power lists products operating use with this mod the manner speci instructions for sa installers. This gr the OEM integrato instructions to ren

The above equipment was tested by SGS Taiwan Ltd., Electronics & Communication Laboratory for compliance with the requirements set forth in the European Standard ETSI EN 300 328 V1.8.1:2012 under R&TTE Directive 1999/5/EC Class II. The results of testing in this report apply to the product system that was tested only. Other similar equipment will not necessarily produce the same results due to production tolerance and measurement uncertainties.

Test By: *Marcus Tseng* **Date:** Jun. 20, 2014
Marcus Tseng / Engineer

Prepared By: *Tiffany Kao* **Date:** Jun. 20, 2014
Tiffany Kao / Clerk

Approved By: *Jim Chang* **Date:** Jun. 20, 2014
Jim Chang / Supervisor

Unless otherwise stated the results shown in this test report refer only to the sample(s) tested and such sample(s) are retained for 90 days only.
除非另有說明，此報告結果僅對測試之樣品負責，同時此樣品僅保留90天。本報告未經本公司書面許可，不可部份複製。

This document is issued by the Company subject to its General Conditions of Service printed overleaf, available on request or accessible at www.sgs.com/terms_and_conditions.htm and, for electronic format documents, subject to Terms and Conditions for Electronic Documents at www.sgs.com/terms_e-document.htm. Attention is drawn to the limitation of liability, indemnification and jurisdiction issues defined therein. Any holder of this document is advised that information contained hereon reflects the Company's findings at the time of its intervention only and within the limits of Client's instructions, if any. The Company's sole responsibility is to its Client and this document does not exonerate parties to a transaction from extending all their rights and obligations under the transaction documents. This document cannot be reproduced except in full, without prior written approval of the Company. Any unauthorized alteration, forgery or falsification of the content or appearance of this document is unlawful and offenders may be prosecuted to the fullest extent of the law.

SGS Taiwan Ltd. No.134,WukungRoad,NewTaipeiIndustrialPark,WukuDistrict,NewTaipeiCity,Taiwan24033新北市五股區新北產業園區五工路134號
台灣檢驗科技股份有限公司 t:(886-2) 2299-3279 f:(886-2) 2298-0488 www.tw.sgs.com

Member of SGS Group