

CSR8670 Bluetooth Modules

SBC2015-B

Specification

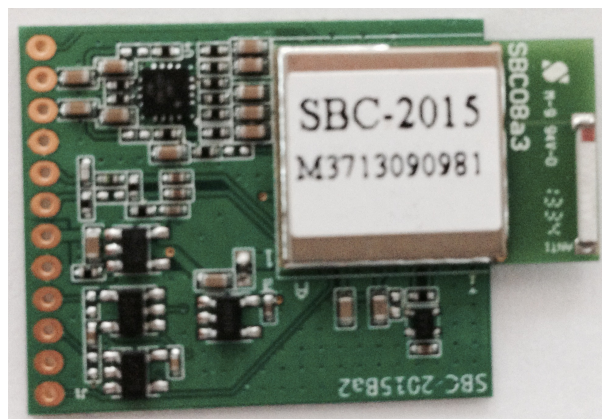

Version 1.0

04-JAN.-2014

© 2014 Smartdesign Technology Co., Ltd. All rights reserved.

Smartdesign Confidential - Information is subject to change without prior notice.

Documentation History

Revision	Description	Date	Remark
V1.0	SBC2015-B preliminary specification released	JAN 2014	

內容目錄

1. Description.....	4
2. Features.....	4
3. Block Diagram.....	5
4. Radio Characteristics	5
5. Electrical Characteristics.....	6
6. Software Diagram.....	7
7. Pin Definition.....	8
8. Mechanical Specification.....	10
9. Reference Schematics.....	11
10. Software specification.....	12
11. Reflow information.....	13

1. Description

SBC2015-B audio transmitter/Receiver is powered by CSR BC8670 technology. That provides a complete 2.4GHz Bluetooth technology for stereo music transmission. The SBC2015-B module is compliant with Bluetooth specification v3.0 EDR, 4.0 LE and supports A2DP, AVRCP, HSP, HFP, and MAP, SPP, PBAP under request. It is the 10dBm module with built-in antenna. Reduce the effort on the RF section when the engineer designs it into the system. Smart Design also customizes the software to meet the requirements from customers.

2. Features

CSR BlueCore8670 Chip.

Bluetooth v3.0 EDR, Bluetooth 4.0 BLE Compliant.

Bluetooth 10dBm RF output power. 10~50 meters transmission distance.

Updated 80 MHz DSP performance.

Single end audio output

UART interface

Supported A2DP1.2, HSP1.2, HFP1.6(HD voice ready) , AVRCP 1.4 ,PBAP1.0 and SPP1.0

True Wireless Stereo (TWS) supported.

Fully configurable with simple AT style commands over UART and Bluetooth connections.

Built-in high performance chip antenna.

PA Integrated and output single end audio interface.

Dimension: 35 X 25 X 3mm.

Castellated SMT pads or 12 PIN pitch 2.0mm connector easy and reliable PCB mounting.

BQE · FCC certified.

3. Block Diagram

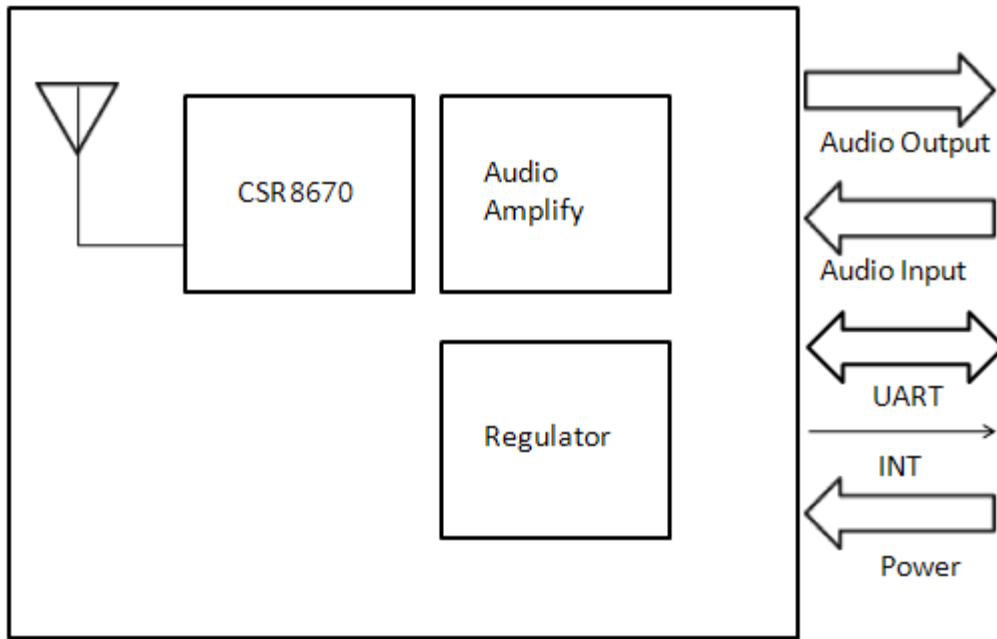

SBC2015-B Module Block Diagram

4. Radio Characteristics

	Frequency (GHz)	MIN	TYP	MAX	BT Spec	Unit
Sensitivity at 0.1%BER	2.402	≤-93	-85	-	≤ -70	dBm
	2.441	≤-93	-85	-		dBm
	2.480	≤-93	-85	-		dBm
RF Transmit Power	2.402	0	3	10	≤ 4	dBm
	2.441	0	3	10		dBm
	2.480	0	3	10		dBm
Initial Carrier Frequency Tolerance	2.402	-	5	75	75	kHz
	2.441	-	5	75		kHz
	2.480	-	5	75		kHz
20dB bandwidth for modulated carrier		-	900	1000	≤1000	kHz
Drift (Five slots packet)		-	15	-	40	kHz
Drift Rate		-	13	-	20	kHz
Δf1 avg "Maximum Modulation"	2.402	140	165	175	140 < Δf1 avg	kHz
	2.441	140	165	175		kHz
	2.480	140	165	175		kHz
Δf2 max "Minimum Modulation"	2.402	115	190	-	115	kHz
	2.441	115	190	-		kHz
	2.480	115	190	-		kHz

5. Electrical Characteristics

Voltage Input

	MIN	Typ.	MAX	Unit
Supply Voltage	3.5	5	5.3	V

Power Consumption

Operate	DUT Role	Connection		Packet Type	Average Current	Unit
	N/A	Deep sleep	With UART host connection		-	55
N/A	Page scan	Page = 1280ms interval Window = 11.25ms		-	219	μA
N/A	Inquiry and page scan	Inquiry = 1280ms interval Page = 1280ms interval Window = 11.25ms		-	378	μA
Master	ACL	Sniff = 500ms, 1 attempt, 0 timeout		DH1	119	μA
Master	ACL	Sniff = 1280ms, 8 attempts, 1 timeout		DH1	109	μA
Master	SCO	Sniff = 100ms, 1 attempt, PCM		HV3	7.6	mA
Master	SCO	Sniff = 100ms, 1 attempt, mono audio codec		HV3	9.8	mA
Master	eSCO	Setting S3, sniff = 100ms, PCM		2EV3	5.8	mA
Master	eSCO	Setting S3, sniff = 100ms, PCM		3EV3	5.4	mA
Master	eSCO	Setting S3, sniff = 100ms, mono audio codec		2EV3	7.9	mA
Master	eSCO	Setting S3, sniff = 100ms, mono audio codec		3EV3	7.5	mA
Slave	ACL	Sniff = 500ms, 1 attempt, 0 timeout		DH1	127	μA
Slave	ACL	Sniff = 1280ms, 8 attempts, 1 timeout		DH1	129	μA
Slave	SCO	Sniff = 100ms, 1 attempt, PCM		HV3	7.8	mA

Voltage Range	3.5V ~ 5.3V
Operating Temperature Range	-30°C ~ 80°C
Storage Temperature Range	-30°C ~ 85°C
Relative Humidity (Operating)	<=90%
Relative Humidity (Storage)	<=90%

6. Software Diagram

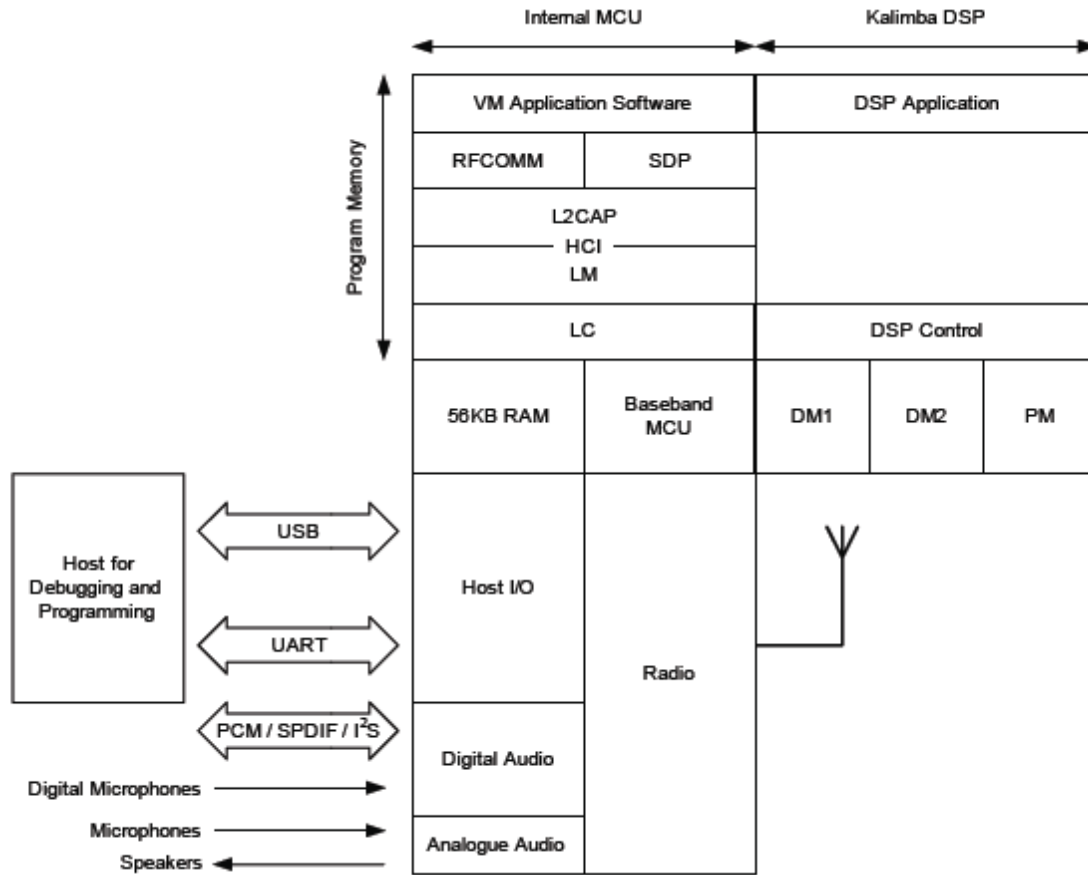

7. Pin Definition

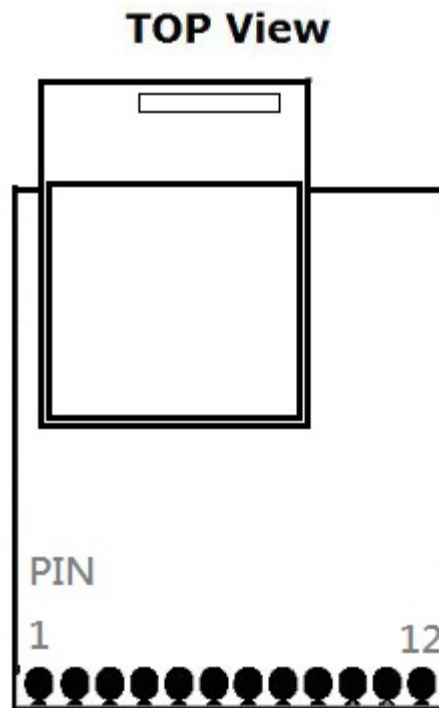

PIN	Name	Type	Note
1	GPIO4	I/O	Reserved. Keep it floating
2	R_SPK	O	Right side audio out put
3	L_SPK	O	Left side side audio output
4	SPK_GND	O	Ground for speaker
5	MIC+	I	Microphone +
6	MIC-	I	Microphone -
7	VCC	PWR	Power input
8	GND	PWR	Ground
9	TX	O	UART TX
10	RX	I	UART RX
11	INT	O	Interrupt
12	GPIO7	I/O	Reserved. Keep it floating

VCC

Supply voltage at this pin with 5 V.

GND

Connect GND pins to the ground plane of the PCB.

RX

RX is used to implement UART data transfer from another device to SBC3525. The UART interface requires an external RS232 transceiver chip. TTL level.

TX

TX is used to implement UART data transfer from SBC3525 to another device. TTL level.

L_SPK

Left channel audio output. The audio output line is the single-ended. Use low impedance ground plane dedicated for the audio signals.

R_SPK

Right channel audio output. The audio output line is the single-ended. Use low impedance ground plane dedicated for the audio signals

SPK_GND

Audio ground. Connect to right and left Audio line.

MIC+ and MIC-

Audio inputs. This audio input can be configured to microphone or line input. Route differential pairs close to each other and use a solid dedicated audio ground plane for the audio signals.

INT

Interrupt output. Normally keep in "Low". Change to "High" when Audio output.

8. Mechanical Specification

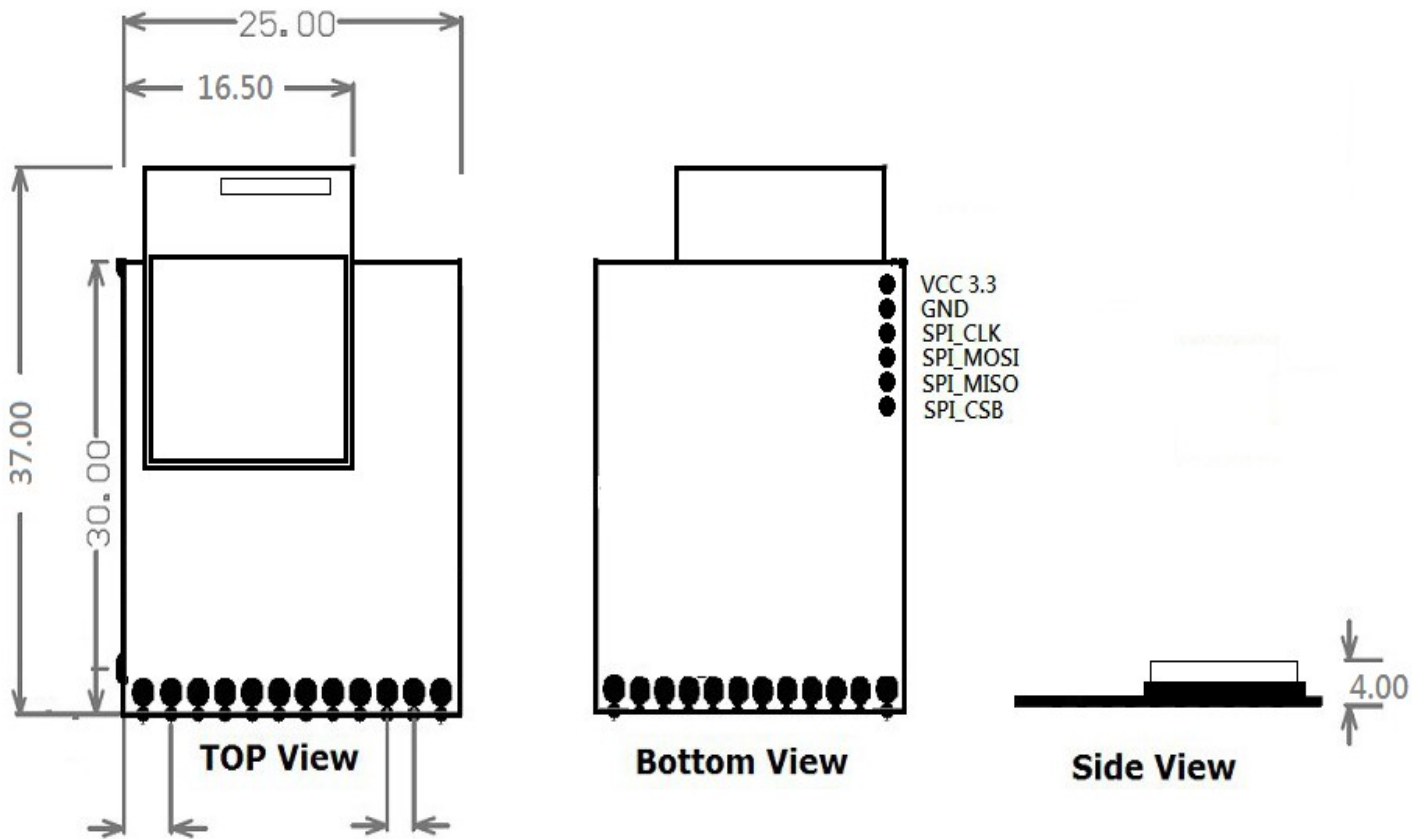
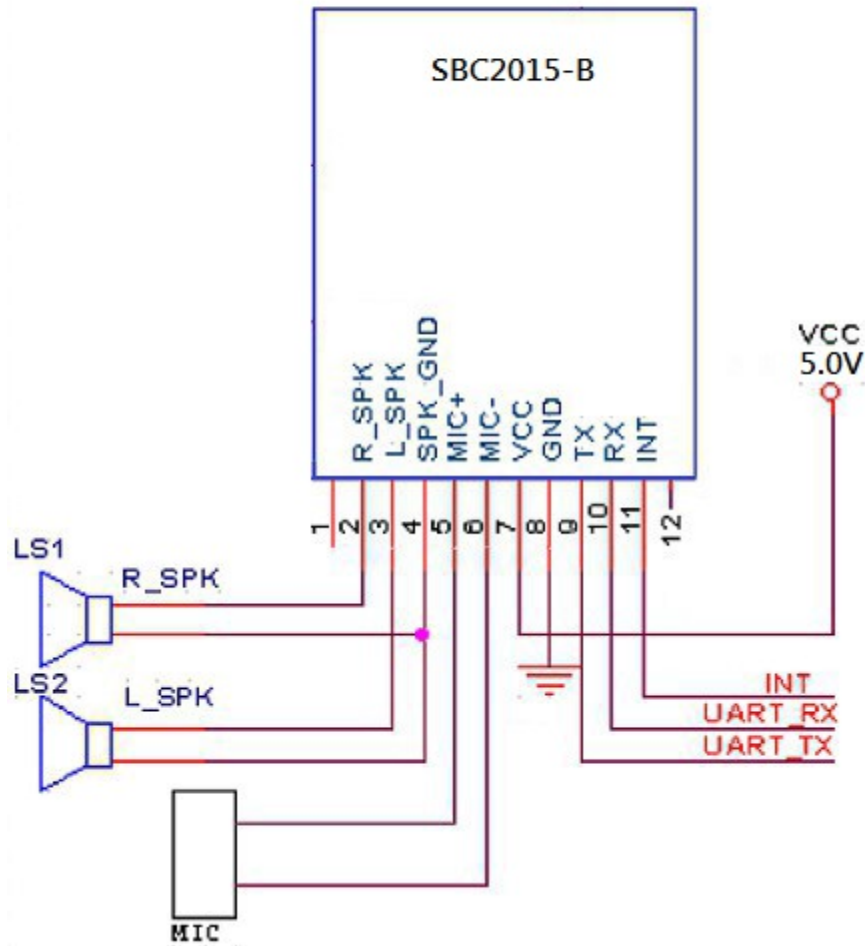

Fig. 1.2 SBC2015-B Mechanical Specification (Unit:mm)

9. Reference Schematics



10. Software specification

Software function

(a) SBC2015-B-SD

SBC2015-B-SD is the Smart Drive software. This software will perform SBC2015-B module itselfes. There is no software effort by user to control this module after ponwe on.

support Profile

Stack / Profile	SBC2015-B-SD BT4.0 module
A2DP	V
HSP	V
HFP	V
AVRCP	V

(b) SBC2015-B-AT

SBC2015-B-AT will act only when you send AT command. Detailed AT command, please check the document "A2DP_AT_Commands"

support Profile

Stack / Profile	SBC2015-B-AT BT4.0 module
A2DP	V
HSP	V
HFP	V
AVRCP	V
MAP	(under Request)
PBAP	V
SPP	(under Request)

11. Reflow information

Reflow Profile Graphic, assuming:

- Kester R905 Sn/4Ag/0.5Cu solder paste.
- All solder ball alloys melt at 217°C.
- Component joints do not exceed temperatures as per J-STD-02

